

CMOSH-4E
SURFACE MOUNT
ENHANCED SPECIFICATION
SILICON SCHOTTKY DIODE

ENHANCED

SPECIFICATION

ULTRAmimi™

SOD-523 CASE

Central™

Semiconductor Corp.

DESCRIPTION:

The CENTRAL SEMICONDUCTOR CMOSH-4E is an Enhanced version of the CMOSH-3 Silicon Schottky Diode in an SOD-523 Surface Mount Package.

ENHANCED SPECIFICATIONS:

- ◆ I_F from 100mA max to 200mA max.
- ◆ BV_R from 30V min to 40V min.
- ◆ V_F from 1.0V max to 0.8V max.

MARKING CODE: 4E

MAXIMUM RATINGS: ($T_A=25^\circ\text{C}$)

- ◆ **Peak Repetitive Reverse Voltage**
- ◆ **Continuous Forward Current**
 Peak Repetitive Forward Current
 Forward Surge Current, $t_p=10\text{ms}$
 Power Dissipation
 Operating and Storage
 Junction Temperature
 Thermal Resistance

SYMBOL	UNITS
V_{RRM}	40 V
I_F	200 mA
I_{FRM}	350 mA
I_{FSM}	750 mA
P_D	250 mW
T_J, T_{stg}	-65 to +150 °C
θ_{JA}	500 °C/W

ELECTRICAL CHARACTERISTICS: ($T_A=25^\circ\text{C}$ unless otherwise noted)

SYMBOL	TEST CONDITIONS	MIN	TYP	MAX	UNITS
I_R	$V_R=25\text{V}$		90	500	nA
I_R	$V_R=25\text{V}, T_A=100^\circ\text{C}$		25	100	μA
◆ BV_R	$I_R=100\mu\text{A}$	40	50		V
V_F	$I_F=2.0\text{mA}$		0.29	0.33	V
◆ V_F	$I_F=15\text{mA}$		0.37	0.42	V
◆ V_F	$I_F=100\text{mA}$		0.61	0.80	V
◆◆ V_F	$I_F=200\text{mA}$		0.65	1.0	V
C_T	$V_R=1.0\text{V}, f=1\text{ MHz}$		7.0		pF
t_{rr}	$I_F=I_R=10\text{mA}, I_{rr}=1.0\text{mA}, R_L=100\Omega$			5.0	ns

- ◆ Enhanced specification.
- ◆◆ Additional Enhanced specification.

R1 (24-May 2004)

**SURFACE MOUNT
ENHANCED SPECIFICATION
SILICON SCHOTTKY DIODE**

SOD-523 CASE - MECHANICAL OUTLINE

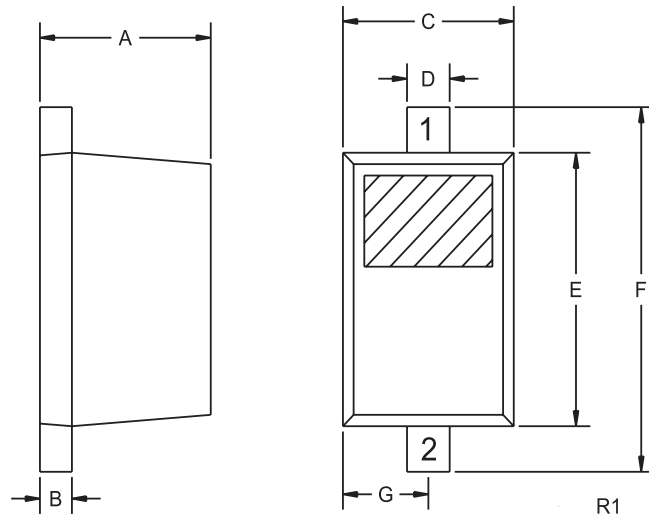

LEAD CODE:

- 1) Cathode
- 2) Anode

MARKING CODE: 4E

SYMBOL	DIMENSIONS			
	INCHES		MILLIMETERS	
	MIN	MAX	MIN	MAX
A	0.020	0.031	0.50	0.80
B	0.004	0.008	0.10	0.20
C	0.028	0.035	0.70	0.90
D	0.008	0.011	0.20	0.28
E	0.039	0.055	1.00	1.40
F	0.055	0.071	1.40	1.80
G	0.016		0.40	

SOD-523 (REV: R1)